

**NCERT QUESTIONS WITH SOLUTIONS**

**EXERCISE : 12.1**

Unless stated otherwise, use  $\pi = \frac{22}{7}$

1. The radii of two circles are 19 cm and 9 cm respectively. Find the radius of the circle which has circumference equal to the sum of the circumferences of the two circles.

**Sol.** The circumference of the circle having radius 19 cm =  $2\pi \times 19$  cm =  $38\pi$  cm  
 The circumference of the circle having radius 9 cm =  $2\pi \times 9$  cm =  $18\pi$  cm  
 Sum of the circumferences of the two circles  
 =  $(38\pi + 18\pi)$  cm =  $56\pi$  cm

Therefore, if  $r$  cm be the radius of the circle which has circumference equal to the sum of the circumference of the two given circles, then

$$2\pi r = 56\pi \Rightarrow r = 28$$

Hence, the required radius is 28 cm.

2. The radii of two circles are 8 cm and 6 cm respectively. Find the radius of the circle having area equal to the sum of the areas of the two circles.

**Sol.** We have,

Radius of circle-I,  $r_1 = 8$  cm

Radius of circle-II,  $r_2 = 6$  cm

$$\therefore \text{Area of circle-I} = \pi r_1^2 = \pi(8)^2 \text{ cm}^2$$

$$\text{Area of circle-II} = \pi r_2^2 = \pi(6)^2 \text{ cm}^2$$

Let the radius of the circle-III be  $R$

$$\therefore \text{Area of circle-III} = \pi R^2$$

$$\Rightarrow \pi(8)^2 + \pi(6)^2 = \pi R^2$$

$$\Rightarrow \pi(8^2 + 6^2) = \pi R^2$$

$$\Rightarrow 8^2 + 6^2 = R^2$$

$$\Rightarrow 64 + 36 = R^2$$

$$\Rightarrow 100 = R^2$$

$$\Rightarrow 10^2 = R^2 \Rightarrow R = 10 \text{ cm}$$

Thus, the radius of the new circle = 10 cm.

3. The fig. depicts an archery target marked with its five scoring regions from the centre outwards as Gold, Red, Blue, Black and White. The diameter of the region representing Gold score is 21 cm and each of the other bands is 10.5 cm wide. Find the area of each of the five scoring regions.

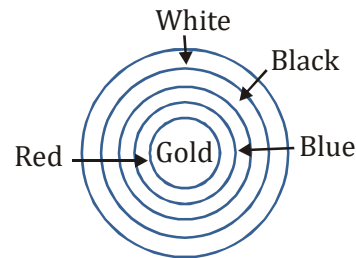

**Sol.** Radius of the Gold scoring region

$$= \frac{21}{2} \text{ cm} = 10.5 \text{ cm} \quad (\because \text{Diameter} = 21 \text{ cm})$$

Therefore, the area of the Gold scoring region (circle)

$$= \pi \times \left(\frac{21}{2}\right)^2 \text{ cm}^2 = \frac{22}{7} \times \frac{21}{2} \times \frac{21}{2} \text{ cm}^2$$

$$= \frac{33 \times 21}{2} \text{ cm}^2 = \frac{693}{2} \text{ cm}^2 = 346.5 \text{ cm}^2$$

Radius of the combined circular region scoring Gold and Red

= radius of Gold scoring region + width of the Red scoring band

$$= 10.5 \text{ cm} + 10.5 \text{ cm} = 21 \text{ cm}$$

The area of the Red scoring region  
= Combined area of Gold and Red scoring region - area of Gold scoring region.

$$= \left\{ \pi \times (21)^2 - \pi \times \left( \frac{21}{2} \right)^2 \right\} \text{cm}^2$$

$$= \pi \times \left\{ (21)^2 - \left( \frac{21}{2} \right)^2 \right\} \text{cm}^2$$

$$= \frac{22}{7} \times \left\{ \left( \frac{21}{2} \times 2 \right)^2 - \left( \frac{21}{2} \right)^2 \right\} \text{cm}^2$$

$$= \frac{22}{7} \times \left( \frac{21}{2} \right)^2 \times (4-1) \text{cm}^2$$

$$= \frac{22}{7} \times \frac{21}{2} \times \frac{21}{2} \times 3 \text{cm}^2$$

$$= \frac{693}{2} \times 3 \text{cm}^2 = \frac{2079}{2} \text{cm}^2 = 1039.5 \text{cm}^2$$

Radius of the combined circular region scoring Gold, Red and Blue.

$$= 10.5 \text{ cm} + 10.5 \text{ cm} + 10.5 \text{ cm} = 31.5 \text{ cm}$$

$$= \frac{63}{2} \text{ cm}$$

Then, area of the Blue scoring region = {Combined area of Gold, Red and Blue scoring regions} - {Combined area of Gold and Red scoring regions}

$$= \pi \times \left( \frac{63}{2} \right)^2 - \pi \times (21)^2$$

$$= \pi \times (21)^2 \times \left( \frac{9}{4} - 1 \right)$$

$$= \frac{22}{7} \times 21 \times 21 \times \frac{5}{4} \text{cm}^2 = \frac{11 \times 63 \times 5}{2} \text{cm}^2$$

$$= 1732.5 \text{cm}^2$$

Similarly, we find the area of the black scoring region

$$= \{ \pi \times (31.5 + 10.5)^2 - \pi \times (31.5)^2 \} \text{cm}^2$$

$$= \left\{ \pi \times (42)^2 - \pi \times \left( \frac{63}{2} \right)^2 \right\} \text{cm}^2$$

$$= \pi \times (21)^2 \times \left\{ 4 - \frac{9}{4} \right\} \text{cm}^2$$

$$= \frac{22}{7} \times 21 \times 21 \times \frac{7}{4} \text{cm}^2$$

$$= \frac{231 \times 21}{2} \text{cm}^2 = \frac{4851}{2} \text{cm}^2 = 2425.5 \text{cm}^2$$

Now, the area of the white scoring region

$$= \{ \pi \times (42 + 10.5)^2 - \pi \times (42)^2 \} \text{cm}^2$$

$$= \left\{ \pi \times \left( \frac{105}{2} \right)^2 - \pi \times (42)^2 \right\} \text{cm}^2$$

$$= \pi \times (21)^2 \times \left\{ \frac{25}{4} - 4 \right\} \text{cm}^2$$

$$= \frac{22}{7} \times 21 \times 21 \times \frac{9}{4} \text{cm}^2$$

$$= \frac{6237}{2} \text{cm}^2 = 3118.5 \text{cm}^2$$

4. The wheels of a car are of diameter 80 cm each. How many complete revolutions does each wheel make in 10 minutes when the car is travelling at a speed of 66 km per hour?

**Sol.** Diameter of the wheel of the car = 80 cm  
Then, the radius of the wheel of the car = 40 cm = 0.4 m

Distance travelled by the car when the wheel of the car completes one revolution

$$= 2\pi \times (0.4) \text{ m} = \frac{4\pi}{5} \text{ m}$$

Let us suppose the wheel of the car completes n revolutions in 10 minutes when travelling at the speed of 66 km per hour. Then distance travelled by making n complete revolution of the wheel in 10

$$\text{minutes} = \left( \frac{4\pi}{5} \times n \right) \text{ m}$$

Also, distance travelled in 60 minutes

$$= 66 \text{ km} = 66 \times 1000 \text{ m}$$

Then the distance travelled in 10 minutes

$$= \frac{66 \times 1000}{60} \times 10 \text{ m} = 11000 \text{ m}$$

Therefore, we have  $\frac{4\pi}{5} \times n = 11000$

(∵ Distance travelled in 10 minutes is same)

$$\Rightarrow \frac{4}{5} \times \frac{22}{7} \times n = 11000$$

$$\Rightarrow n = \frac{11000 \times 5 \times 7}{4 \times 22} = 125 \times 35 = 4375$$

Hence, the number of complete revolutions made by the wheel in 10 minutes is 4375.

5. Tick the correct answer in the following and justify your choice. If the perimeter and area of a circle are numerically equal, then the radius of the circle is

- (A) 2 units                      (B)  $\pi$  units  
(C) 4 units                      (D) 7 units

**Sol.** (A) We have

$$\pi r^2 = 2\pi r$$

$$\Rightarrow \pi r^2 - 2\pi r = 0$$

$$\Rightarrow r^2 - 2r = 0$$

$$\Rightarrow r(r - 2) = 0$$

$$\Rightarrow r = 0 \text{ or } r = 2$$

But r cannot be zero

$$\therefore r = 2 \text{ units.}$$

Thus, the radius of circle is 2 units.

**EXERCISE : 12.2**

1. Find the area of a sector of a circle with radius 6 cm if angle of the sector is  $60^\circ$ .

**Sol.** Radius,  $r = 6$  cm; sector angle,  $\theta = 60$  degrees

Area of the sector

$$= \frac{\theta}{360} \times \pi r^2 = \frac{60}{360} \times \frac{22}{7} \times (6)^2 \text{ cm}^2$$

$$= \frac{1}{6} \times \frac{22}{7} \times (6)^2 \text{ cm}^2 = \frac{132}{7} \text{ cm}^2$$

2. Find the area of a quadrant of a circle whose circumference is 22 cm.

**Sol.** Let radius of the circle = r

$$\therefore 2\pi r = 22$$

$$\Rightarrow 2 \times \frac{22}{7} \times r = 22$$

$$\Rightarrow r = 22 \times \frac{7}{22} \times \frac{1}{2} = \frac{7}{2} \text{ cm}$$

Here,  $\theta = 90^\circ$

∴ Area of the  $\frac{1}{4}$  part of the circle or area

of quadrant of the circle =  $\frac{\theta}{360} \times \pi r^2$

$$= \frac{90^\circ}{360^\circ} \times \frac{22}{7} \left(\frac{7}{2}\right)^2 \text{ cm}^2$$

$$= \frac{1}{4} \times \frac{22}{7} \times \frac{7}{2} \times \frac{7}{2} \text{ cm}^2 = \frac{77}{8} \text{ cm}^2$$

3. The length of the minute hand of a clock is 14 cm. Find the area swept by the minute hand in 5 minutes.

**Sol.** We know that in 1 hour (i.e., 60 minutes), the minute hand rotates  $360^\circ$ .

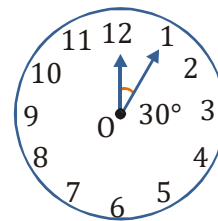

In 5 minutes, minute hand will rotate at an angle

$$= \frac{360^\circ}{60} \times 5 = 30^\circ$$

Therefore, the area swept by the minute hand in 5 minutes will be the area of a sector of  $30^\circ$  in a circle of 14 cm radius.

$$\text{Area of sector of angle } \theta = \frac{\theta}{360^\circ} \times \pi r^2$$

$$\begin{aligned} \text{Area of sector of } 30^\circ &= \frac{30^\circ}{360^\circ} \times \frac{22}{7} \times 14 \times 14 \\ &= \frac{22}{12} \times 2 \times 14 = \frac{11 \times 14}{3} = \frac{154}{3} \text{ cm}^2 \end{aligned}$$

Therefore, the area swept by the minute hand in 5 minutes is  $\frac{154}{3} \text{ cm}^2$

4. A chord of a circle of radius 10 cm subtends a right angle at the centre. Find the area of the corresponding: (i) minor segment (ii) major sector. (Use  $\pi = 3.14$ )

**Sol.** Here, the radius of the circle is  $r = 10$  cm. Sector angle of the minor sector made corresponding to the chord AB is  $90^\circ$

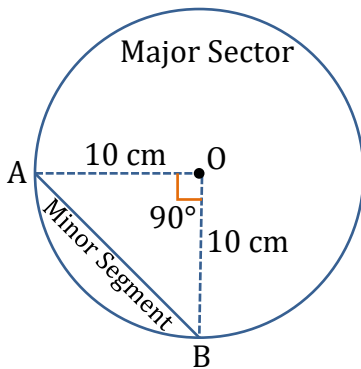

Now, the area of the minor sector

$$\begin{aligned} &= \frac{90}{360} \times \pi r^2 \\ &= \frac{1}{4} \times \pi \times (10)^2 \text{ cm}^2 = \frac{1}{4} \times 3.14 \times 100 \text{ cm}^2 \\ &= \frac{314}{4} \text{ cm}^2 = 78.5 \text{ cm}^2 \end{aligned}$$

Then, the area of the minor segment = The area of the minor sector - The area of the  $\Delta OAB$

$$= 78.5 \text{ cm}^2 - \frac{1}{2} \times OA \times OB (\because \angle AOB = 90^\circ)$$

$$= 78.5 \text{ cm}^2 - \frac{1}{2} \times 10 \times 10 \text{ cm}^2$$

$$= (78.5 - 50) \text{ cm}^2 = 28.5 \text{ cm}^2$$

The area of the major sector

$$= \left( \frac{360 - 90}{360} \right) \times \pi r^2$$

$$= \frac{270}{360} \times 3.14 \times (10)^2 \text{ cm}^2$$

$$= \frac{3}{4} \times 314 \text{ cm}^2 = \frac{3 \times 157}{2} \text{ cm}^2 = 235.5 \text{ cm}^2$$

5. In a circle of radius 21 cm, an arc subtends an angle of  $60^\circ$  at the centre. Find

- (i) The length of the arc  
(ii) Area of the sector formed by the arc  
(iii) Area of the segment formed by the corresponding chord

**Sol.** Here, radius = 21 cm and  $\theta = 60^\circ$

- (i) Circumference of the circle =  $2\pi r$

$$= 2 \times \frac{22}{7} \times 21 \text{ cm} = 2 \times 22 \times 3 \text{ cm} = 132 \text{ cm}$$

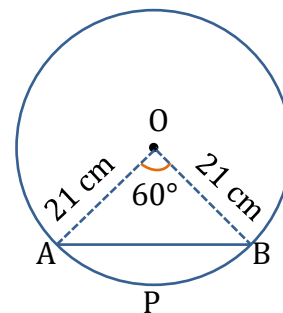

$\therefore$  Length of arc APB

$$= \frac{\theta}{360^\circ} \times 2\pi r = \frac{60^\circ}{360^\circ} \times 132 \text{ cm}$$

$$= \frac{1}{6} \times 132 \text{ cm} = 22 \text{ cm}$$

(ii) Area of the sector with sector angle  $60^\circ = \frac{60^\circ}{360^\circ} \times \pi r^2 = \frac{60^\circ}{360^\circ} \times \frac{22}{7} \times 21 \times 21 \text{ cm}^2$   
 $= 11 \times 21 \text{ cm}^2 = 231 \text{ cm}^2$

(iii) Area of the segment APB = [Area of the sector AOB] - [Area of  $\Delta AOB$ ] .....(1)

In  $\Delta AOB$ ,  $OA = OB = 21 \text{ cm}$

$\therefore \angle A = \angle B = 60^\circ$  [ $\because \angle O = 60^\circ$ ]

$\Rightarrow AOB$  is an equilateral triangle.

$\therefore AB = 21 \text{ cm}$

$\therefore$  area of  $\Delta AOB = \frac{\sqrt{3}}{4} (\text{side})^2$   
 $= \frac{\sqrt{3}}{4} \times 21 \times 21 \text{ cm}^2 = \frac{441\sqrt{3}}{4} \text{ cm}^2$  ... (2)

From (1) and (2), we have

Area of segment

$= [231 \text{ cm}^2] - \left[ \frac{441\sqrt{3}}{4} \text{ cm}^2 \right]$   
 $= \left( 231 - \frac{441\sqrt{3}}{4} \right) \text{ cm}^2$   
 $= 40.047 \text{ cm}^2$

6. A chord of a circle of radius 15 cm subtends an angle of  $60^\circ$  at the centre. Find the areas of the corresponding minor and major segments of the circle. (Use  $\pi = 3.14$  and  $\sqrt{3} = 1.73$ )

**Sol.** Here, radius ( $r$ ) = 15 cm and Sector angle ( $\theta$ ) =  $60^\circ$

$\therefore$  Area of the sector  
 $= \frac{\theta}{360^\circ} \times \pi r^2 = \frac{60^\circ}{360^\circ} \times \frac{314}{100} \times 15 \times 15 \text{ cm}^2$   
 $= \frac{11775}{100} \text{ cm}^2 = 117.75 \text{ cm}^2$

Since  $\angle O = 60^\circ$  and  $OA = OB = 15 \text{ cm}$   
 $\therefore AOB$  is an equilateral triangle.

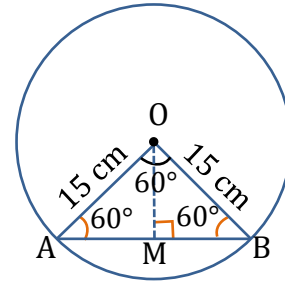

$\Rightarrow AB = 15 \text{ cm}$  and  $\angle A = 60^\circ$

Draw  $OM \perp AB$ , in  $\Delta AMO$

$\therefore \frac{OM}{OA} = \sin 60^\circ = \frac{\sqrt{3}}{2}$

$\Rightarrow OM = OA \times \frac{\sqrt{3}}{2} = \frac{15\sqrt{3}}{2} \text{ cm}$

Now,  $\text{ar}(\Delta AOB) = \frac{1}{2} \times AB \times OM$

$= \frac{1}{2} \times 15 \times 15 \times \frac{\sqrt{3}}{2} \text{ cm}^2 = \frac{225\sqrt{3}}{4} \text{ cm}^2$

$= \frac{225 \times 1.73}{4} \text{ cm}^2 = 97.3125$

Now area of the minor segment

$= (\text{Area of minor sector}) - (\text{ar } \Delta AOB)$   
 $= (117.75 - 97.3125) \text{ cm}^2 = 20.4375 \text{ cm}^2$

Area of the major segment

$= (\text{Area of the circle}) - (\text{Area of the minor segment})$

$= \pi r^2 - 20.4375 \text{ cm}^2$

$= \left[ \frac{314}{100} \times 15^2 \right] - 20.4375 \text{ cm}^2$

$= 706.5 - 20.4375 \text{ cm}^2 = 686.0625 \text{ cm}^2$

7. A chord of a circle of radius 12 cm subtends an angle of  $120^\circ$  at the centre. Find the area of the corresponding segment of the circle. (Use  $\pi = 3.14$  and  $\sqrt{3} = 1.73$ )

**Sol.** Here  $\theta = 120^\circ$  and  $r = 12$  cm

$$\begin{aligned} \therefore \text{Area of the sector} &= \frac{\theta}{360^\circ} \times \pi r^2 \\ &= \frac{120}{360} \times \frac{314}{100} \times 12 \times 12 \text{ cm}^2 \\ &= \frac{314 \times 4 \times 12}{100} \text{ cm}^2 = \frac{15072}{100} \text{ cm}^2 \\ &= 150.72 \text{ cm}^2 \quad \dots(\text{i}) \end{aligned}$$

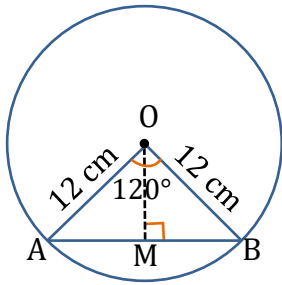

Now, area of  $\triangle AOB = \frac{1}{2} \times AB \times OM \quad \dots(\text{ii})$

[ $\because OM \perp AB$ ]

In  $\triangle OAB$ ,  $\angle O = 120^\circ$

$$\Rightarrow \angle A + \angle B = 180^\circ - 120^\circ = 60^\circ$$

$$\because OB = OA = 12 \text{ cm}$$

$$\Rightarrow \angle A = \angle B = 30^\circ$$

$$\text{So, } \frac{OM}{OA} = \sin 30^\circ = \frac{1}{2} \Rightarrow OM = OA \times \frac{1}{2}$$

$$\Rightarrow OM = 12 \times \frac{1}{2} = 6 \text{ cm}$$

$$\text{and } \frac{AM}{OA} = \cos 30^\circ = \frac{\sqrt{3}}{2}$$

$$\Rightarrow AM = \frac{\sqrt{3}}{2} OA = \frac{\sqrt{3}}{2} \times 12 = 6\sqrt{3} \text{ cm}$$

$$\therefore AB = 2(AM) = 12\sqrt{3} \text{ cm.}$$

Now, from (ii),

$$\text{Area of } \triangle AOB = \frac{1}{2} \times AB \times OM$$

$$= \frac{1}{2} \times 12\sqrt{3} \times 6 \text{ cm}^2 = 36\sqrt{3} \text{ cm}^2$$

$$= 36 \times 1.73 \text{ cm}^2 = 62.28 \text{ cm}^2 \quad \dots(\text{iii})$$

From (i) and (iii)

Area of the minor segment

$$= (\text{Area of sector}) - (\text{Area of } \triangle AOB)$$

$$= (150.72 \text{ cm}^2) - (62.28 \text{ cm}^2) = 88.44 \text{ cm}^2$$

8. A horse is tied to a peg at one corner of a square shaped grass field of side 15 m by means of a 5 m long rope. Find



- (i) The area of that part of the field in which the horse can graze.
- (ii) The increase in the grazing area if the rope were 10 m long instead of 5 m. (Use  $\pi = 3.14$ )

**Sol.** Here,  $r = 5$  m,  $\theta = 90^\circ$

- (i) The required area (Grazing area for horse) = The area of the sector OAB

$$= \frac{90}{360} \times \pi r^2 = \frac{1}{4} \times 3.14 \times (5)^2 \text{ m}^2$$

$$= \frac{1}{4} \times 78.50 \text{ m}^2 = 19.625 \text{ m}^2$$

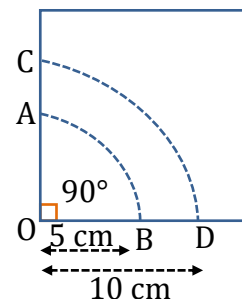

- (ii) Now, the radius for the sector OCD = 10 m and sector angle =  $90^\circ$   
The area of the sector OCD

$$= \frac{90}{360} \times \pi \times (10)^2 \text{ m}^2$$

$$= \frac{1}{4} \times 3.14 \times 100 \text{ m}^2 = 78.5 \text{ m}^2$$

Therefore, the increase of grazing area  
 = The area of sector OCD - The area of sector OAB =  $78.5 \text{ m}^2 - 19.625 \text{ m}^2$   
 =  $58.875 \text{ m}^2$

9. A brooch is made with silver wire in the form of a circle with diameter 35 mm. The wire is also used in making 5 diameters which divide the circle into 10 equal sectors as shown in fig. Find

(i) The total length of the silver wire required.

(ii) the area of each sector of the brooch.



**Sol.** Diameter of the circle = 35 mm

$$\therefore \text{Radius } (r) = \frac{35}{2} \text{ mm}$$

(i) Circumference =  $2\pi r$

$$= 2 \times \frac{22}{7} \times \frac{35}{2} \text{ mm} = 22 \times 5 = 110 \text{ mm}$$

Length of 1 piece of wire used to make diameter to divide the circle into 10 equal sectors = 35 mm

$$\therefore \text{Length 5 pieces} = 5 \times 35 = 175 \text{ mm}$$

$$\therefore \text{Total length of the silver wire}$$

$$= 110 + 175 \text{ mm} = 285 \text{ mm}$$

(ii) Since the circle is divided into 10 equal sectors,

$$\therefore \text{Sector angle } \theta = \frac{360^\circ}{10} = 36^\circ$$

$$\Rightarrow \text{Area of each sector} = \frac{\theta}{360^\circ} \times \pi r^2$$

$$= \frac{36^\circ}{360^\circ} \times \frac{22}{7} \times \frac{35}{2} \times \frac{35}{2} \text{ mm}^2$$

$$= \frac{11 \times 35}{4} \text{ mm}^2$$

$$= \frac{385}{4} \text{ mm}^2$$

10. An umbrella has 8 ribs which are equally spaced. Assuming umbrella to be a flat circle of radius 45 cm, find the area between the two consecutive ribs of the umbrella.

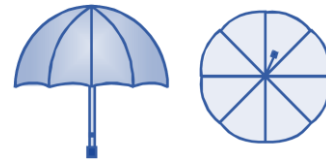

**Sol.** Here, radius ( $r$ ) = 45 cm

Since circle is divided in 8 equal parts,

$\therefore$  Sector angle corresponding to each

$$\text{part } \theta = \frac{360^\circ}{8} = 45^\circ$$

$\Rightarrow$  Area of a sector (part)

$$= \frac{\theta}{360^\circ} \times \pi r^2 = \frac{45^\circ}{360^\circ} \times \frac{22}{7} \times 45 \times 45 \text{ cm}^2$$

$$= \frac{11 \times 45 \times 45}{4 \times 7} \text{ cm}^2 = \frac{22275}{28} \text{ cm}^2$$

$\therefore$  The required area between the two

$$\text{ribs} = \frac{22275}{28} \text{ cm}^2$$

11. A car has two wipers which do not overlap. Each wiper has a blade of length 25 cm sweeping through an angle of  $115^\circ$ . Find the total area cleaned at each sweep of the blades.

**Sol.** Here, one blade of a wipe sweeps a sector area of a circle of radius 25 cm.  
sector angle =  $115^\circ$

i.e.,  $r = 25$  cm and  $\theta = 115^\circ$

The area covered by one blade

$$= \frac{115}{360} \times \pi \times (25)^2 \text{ cm}^2$$

Then, the area covered by two blades

$$= 2 \times \frac{115}{360} \times \frac{22}{7} \times 625 \text{ cm}^2$$

$$= \frac{23}{18} \times \frac{11}{7} \times 625 \text{ cm}^2$$

$$= \frac{158125}{126} \text{ cm}^2$$

**12.** To warn ships for underwater rocks, a lighthouse spreads a red coloured light over a sector of angle  $80^\circ$  to a distance of 16.5 km. Find the area of the sea over which the ships are warned.

(Use  $\pi = 3.14$ )

**Sol.** Here, Radius ( $r$ ) = 16.5 km and

Sector angle ( $\theta$ ) =  $80^\circ$

$\therefore$  Area of the sea surface over which the

$$\text{ships are warned} = \frac{\theta}{360^\circ} \times \pi r^2$$

$$= \frac{80^\circ}{360^\circ} \times \frac{314}{100} \times \frac{165}{10} \times \frac{165}{10} \text{ km}^2$$

$$= \frac{157 \times 11 \times 11}{100} \text{ km}^2 = \frac{18997}{100} \text{ km}^2$$

$$= 189.97 \text{ km}^2$$

**13.** A round table cover has six equal designs as shown in fig. If the radius of the cover is 28 cm, find the cost of making the designs at the rate of Rs 0.35 per  $\text{cm}^2$ .

(Use = 1.7)

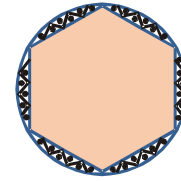

**Sol.**

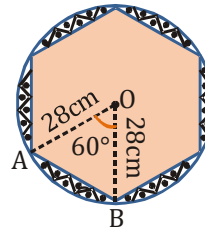

Here,  $r = 28$  cm.  $\theta = \frac{360^\circ}{6} = 60^\circ$

In the figure  $\Delta OAB$  is equilateral having side 28 cm.

The area of one shaded designed portion = The area of the sector OAB – The area of the  $\Delta OAB$

$$= \left\{ \frac{60}{360} \times \pi \times (28)^2 - \frac{\sqrt{3}}{4} \times (28)^2 \right\} \text{ cm}^2$$

$$= \left( \frac{1}{6} \times \frac{22}{7} \times 28 \times 28 - \frac{1.7}{4} \times 28 \times 28 \right) \text{ cm}^2$$

$$= \left( \frac{11}{3} \times 112 - 1.7 \times 196 \right) \text{ cm}^2$$

$$= \left( \frac{1232}{3} - 333.2 \right) \text{ cm}^2$$

The total area of six designed portions

$$= 6 \times \left( \frac{1232}{3} - 333.2 \right) \text{ cm}^2$$

$$= 2464 - 1999.2 \text{ cm}^2 = 464.8 \text{ cm}^2$$

The total cost of making the designs at the rate of ₹ 0.35 per  $\text{cm}^2$

$$= ₹ 0.35 \times 464.8 = ₹ 162.68.$$

14. Tick the correct answer in the following :  
Area of a sector of angle  $p$  (in degree) of a circle with radius  $R$  is.

- (A)  $\frac{p}{180} \times 2\pi R$                       (B)  $\frac{p}{180} \times \pi R^2$   
(C)  $\frac{p}{360} \times 2\pi R$                       (D)  $\frac{p}{720} \times 2\pi R^2$

**Sol.** (D) Here, radius ( $r$ ) =  $R$   
Angle of sector ( $\theta$ ) =  $p^\circ$   
 $\therefore$  Area of the sector

$$= \frac{\theta}{360} \times \pi r^2 = \frac{p}{360^\circ} \times \pi R^2$$

$$= \frac{2}{2} \times \left( \frac{p}{360^\circ} \times \pi R^2 \right) = \frac{p}{720^\circ} \times 2\pi R^2$$

**EXERCISE : 12.3**

Unless stated otherwise, use  $\pi = \frac{22}{7}$

1. Find the area of the shaded region in fig, if  $PQ = 24$ ,  $PR = 7$  cm and  $O$  is the centre of the circle.

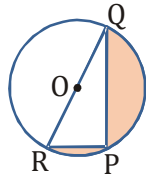

**Sol.** In the figure,  $\angle RPQ = 90^\circ$   
(Angle subtended by a diameter on the circumference)  
Therefore,  $\Delta RPQ$  is right angled at  $P$ ,  
 $RP = 7$  cm and  $PQ = 24$  cm  
Then by Pythagoras Theorem, we have  
 $QR^2 = RP^2 + PQ^2 = (7)^2 + (24)^2 = 625$   
 $QR = 25$  cm  
 $\therefore$  The radius of the circle =  $\frac{25}{2}$  cm  
Now, the area of the shaded region  
(see figure)  
= Area of semicircle – area of triangle

$$= \frac{1}{2} \pi r^2 - \frac{1}{2} \times RP \times PQ$$

$$= \left\{ \frac{1}{2} \times \frac{22}{7} \times \left( \frac{25}{2} \right)^2 - \frac{1}{2} \times 7 \times 24 \right\} \text{cm}^2$$

$$= \left( \frac{6875}{28} - 84 \right) \text{cm}^2 = \frac{4523}{28} \text{cm}^2$$

$$= 161.535 \text{cm}^2$$

2. Find the area of the shaded region in fig., if radii of the two concentric circles with centre  $O$  are 7 cm and 14 cm respectively and  $\angle AOC = 40^\circ$ .

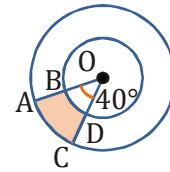

**Sol.** Radius of the outer circle = 14 cm and  
 $\theta = 40^\circ$

$\therefore$  Area of the sector AOC

$$= \frac{40^\circ}{360^\circ} \times \frac{22}{7} \times 14 \times 14 \text{cm}^2$$

$$= \frac{1}{9} \times 22 \times 2 \times 14 \text{cm}^2 = \frac{616}{9} \text{cm}^2$$

Radius of the inner circle = 7 cm and  
 $\theta = 40^\circ$

$\therefore$  Area of the sector BOD

$$= \frac{40^\circ}{360^\circ} \times \frac{22}{7} \times 7 \times 7 \text{cm}^2$$

$$= \frac{1}{9} \times 22 \times 7 \text{cm}^2 = \frac{154}{9} \text{cm}^2$$

Now, area of the shaded region  
= Area of sector AOC – Area of sector BOD

$$= \frac{616}{9} - \frac{154}{9} \text{cm}^2 = \frac{1}{9} (616 - 154) \text{cm}^2$$

$$= \frac{1}{9} \times 462 \text{cm}^2 = \frac{154}{3} \text{cm}^2 = 51.34 \text{cm}^2$$

3. Find the area of the shaded region in fig., if ABCD is a square of side 14 cm and APD and BPC are semicircles.

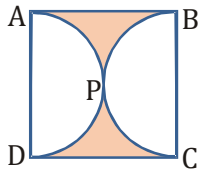

**Sol.** The area of the square ABCD =  $(14)^2 \text{ cm}^2$   
 =  $196 \text{ cm}^2$  ( $\because$  side of the square 14 cm)

The sum of the areas of the semicircles APD and BPC

$$= 2 \times \{\text{area of semicircle APD}\}$$

( $\because$  the areas of the two semicircles are equal)

$$= 2 \times \left( \frac{1}{2} \pi r^2 \right) = \pi \times \left( \frac{AD}{2} \right)^2 = \pi \times \left( \frac{14}{2} \right)^2$$

( $\because$  AD is diameter of the semicircle APD)

$$= \frac{22}{7} \times 49 \text{ cm}^2 = 154 \text{ cm}^2$$

The area of the shaded region

= The area of the square ABCD – The sum of the areas of the semicircles APD and BPC.

$$= 196 \text{ cm}^2 - 154 \text{ cm}^2 = 42 \text{ cm}^2$$

4. Find the area of the shaded region in fig., where a circular arc of radius 6 cm has been drawn with vertex O of an equilateral triangle OAB of side 12 cm as centre.

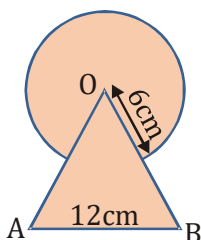

**Sol.** Area of the circle with radius 6 cm

$$= \pi r^2 = \frac{22}{7} \times 6 \times 6 \text{ cm}^2 = \frac{792}{7} \text{ cm}^2$$

Area of equilateral triangle, having side  $a = 12 \text{ cm}$ , is given by

$$\frac{\sqrt{3}}{4} a^2 = \frac{\sqrt{3}}{4} \times 12 \times 12 \text{ cm}^2 = 36\sqrt{3} \text{ cm}^2$$

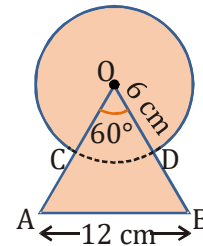

$\because$  Each angle of an equilateral triangle =  $60^\circ$

$$\therefore \angle AOB = 60^\circ$$

$\therefore$  Area of sector COD

$$= \frac{\theta}{360^\circ} \times \pi r^2 = \frac{60^\circ}{360^\circ} \times \frac{22}{7} \times 6 \times 6 \text{ cm}^2$$

$$= \frac{22 \times 6}{7} \text{ cm}^2 = \frac{132}{7} \text{ cm}^2$$

Now, area of the shaded region,

= [Area of the circle] + [Area of the equilateral triangle] – [Area of the sector COD]

$$= \left( \frac{792}{7} + 36\sqrt{3} - \frac{132}{7} \right) \text{ cm}^2$$

$$= \left( \frac{660}{7} + 36\sqrt{3} \right) \text{ cm}^2$$

$$= 156.64 \text{ cm}^2$$

5. From each corner of a square of side 4 cm a quadrant of a circle of radius 1 cm is cut and also a circle of diameter 2 cm is cut as shown in fig. Find the area of the remaining portion of the square.

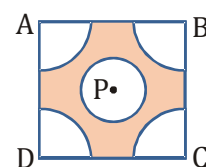

**Sol.** Side of the square = 4 cm

$$\therefore \text{Area of the square ABCD} = 4 \times 4 \text{ cm}^2 = 16 \text{ cm}^2$$

$\therefore$  Each corner has a quadrant of a circle of radius 1 cm.

$$\therefore \text{Area of all the 4 quadrants} = 4 \times \frac{1}{4} \pi r^2 = \pi r^2$$

$$= \frac{22}{7} \times 1 \times 1 \text{ cm}^2 = \frac{22}{7} \text{ cm}^2$$

Diameter of the middle circle = 2 cm

$\therefore$  Radius of the middle circle = 1 cm

$\therefore$  Area of the middle circle

$$= \pi r^2 = \frac{22}{7} \times 1 \times 1 \text{ cm}^2 = \frac{22}{7} \text{ cm}^2$$

Now, area of the shaded region

= [Area of the square ABCD] - [(Area of the 4 quadrant of a circle) + (Area of the middle circle)]

$$= [16 \text{ cm}^2] - \left[ \left( \frac{22}{7} + \frac{22}{7} \right) \text{ cm}^2 \right]$$

$$= 16 \text{ cm}^2 - 2 \times \frac{22}{7} \text{ cm}^2$$

$$= 16 \text{ cm}^2 - \frac{44}{7} \text{ cm}^2 = \frac{112 - 44}{7} \text{ cm}^2$$

$$= \frac{68}{7} \text{ cm}^2 = 9.714 \text{ cm}^2$$

6. In a circular table cover of radius 32 cm, a design is formed leaving an equilateral triangle ABC in the middle as shown in fig. Find the area of the design.

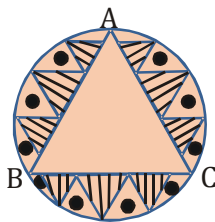

**Sol.**

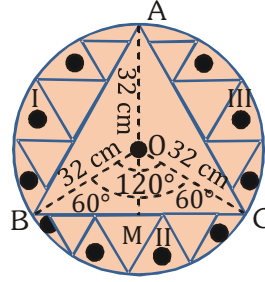

O is the centre of the circular table cover and radius = 32 cm.  $\triangle ABC$  is equilateral.

Join OA, OB, OC.

Now,  $\angle AOB = \angle BOC = \angle COA = 120^\circ$

In  $\triangle OBC$ , we have  $OB = OC$

Draw  $OM \perp BC$ .

$\Rightarrow \angle BOM = \angle COM = 60^\circ$

( $\because \triangle OMB \cong \triangle OMC$  by RHS congruence)

Now,  $\frac{BM}{OB} = \sin 60^\circ$

$$\Rightarrow \frac{BM}{32} = \frac{\sqrt{3}}{2}$$

$$\Rightarrow BM = 16\sqrt{3} \text{ cm}$$

Then,  $BC = 2 \times BM$

$$= 32\sqrt{3} \text{ cm}$$

Thus, the side of the equilateral triangle ABC

$$= 32\sqrt{3} \text{ cm}$$

The area of the shaded region (designed)

= The area of circle - area of  $\triangle ABC$

$$= \left\{ \pi \times (32)^2 - \frac{\sqrt{3}}{4} \times (32\sqrt{3})^2 \right\} \text{ cm}^2$$

$$= \left( \frac{22}{7} \times 32 \times 32 - \frac{\sqrt{3}}{4} \times 32 \times 32 \times 3 \right) \text{ cm}^2$$

$$= \left( \frac{22528}{7} - 768\sqrt{3} \right) \text{ cm}^2$$

$$= 1888.07 \text{ cm}^2$$

7. In fig., ABCD is a square of side 14 cm. With centres A, B, C and D, four circles are drawn such that each circle touch externally two of the remaining three circles. Find the area of the shaded region.

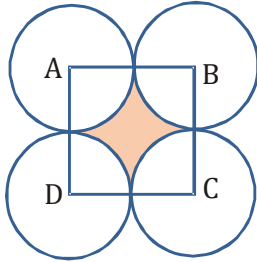

Sol.

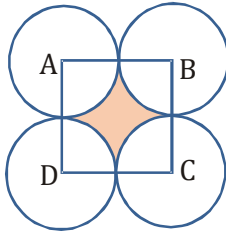

Side of the square ABCD = 14 cm

$$\therefore \text{Area of the square ABCD} = 14 \times 14 \text{ cm}^2 = 196 \text{ cm}^2$$

$\therefore$  Circles touch each other

$$\text{Radius of the circle} = \frac{14}{2} = 7 \text{ cm}$$

Now, area of a sector of radius 7 cm and sector angle  $\theta$  as  $90^\circ$

$$= \frac{90^\circ}{360^\circ} \times \frac{22}{7} \times 7 \times 7 \text{ cm}^2 = \frac{11 \times 7}{2} \text{ cm}^2$$

Area of 4 sectors

$$= 4 \times \left[ \frac{11 \times 7}{2} \right] = 2 \times 11 \times 7 \text{ cm}^2 = 154 \text{ cm}^2$$

Area of the shaded region = [Area of the square ABCD] – [Area of the 4 sectors]

$$= 196 \text{ cm}^2 - 154 \text{ cm}^2$$

$$= 42 \text{ cm}^2$$

8. Fig. depicts a racing track whose left and right ends are semicircular.

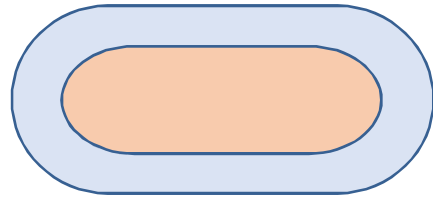

The distance between the two inner parallel line segments is 60 m and they are each 106 m long. If the track is 10 m wide, find:

- (i) The distance around the track along its inner edge  
(ii) The area of the track.

- Sol. (i) The distance around the track along the inner edge (as seen from figure)

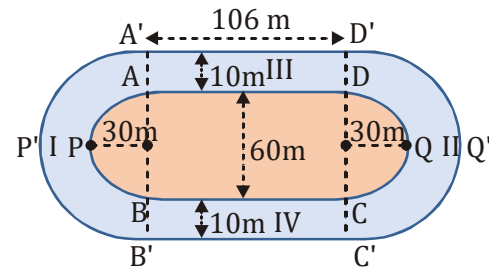

$$= \text{Circumference of APB} + \text{BC} + \text{Circumference of CQD} + \text{AD}$$

$$= \{\pi \times 30 + 106 + \pi \times 30 + 106\} \text{ m}$$

$$= \{60\pi + 212\} \text{ m}$$

$$= \left\{ 60 \times \frac{22}{7} + 212 \right\} = \frac{2804}{7} \text{ m}$$

- (ii) Area of region I =  $\frac{1}{2}\pi \times (40)^2 - \frac{1}{2}\pi \times (30)^2$

$$\{\because \text{outer radius} = 30 \text{ m} + 10 \text{ m} = 40 \text{ m}\}$$

$$= \frac{1}{2}\pi \times 700 \text{ m}^2 = \frac{1}{2} \times \frac{22}{7} \times 700 \text{ m}^2$$

$$= 1100 \text{ m}^2$$

Similarly, area of the region II = 1100 m<sup>2</sup>

Area of the region III (rectangle)  
 $= 106 \times 10 = 1060 \text{ m}^2$

Similarly, the area of the region IV =  $1060 \text{ m}^2$

Then, the total area of the track  
 $= 2 \times 1100 \text{ m}^2 + 2 \times 1060 \text{ m}^2$   
 $= (2200 + 2120) \text{ m}^2 = 4320 \text{ m}^2$

9. In fig., AB and CD are two diameters of a circle (with centre O) perpendicular to each other and OD is the diameter of the smaller circle. If OA = 7 cm. find the area of the shaded region.

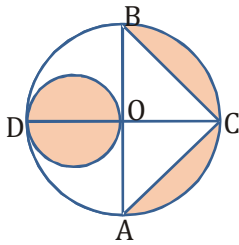

**Sol.** O is the centre of the circle, OA = 7 cm  
 $\Rightarrow AB = 2(OA) = 2 \times 7 = 14 \text{ cm}$   
 OC = OA = 7 cm  
 $\therefore$  AB and CD are perpendicular to each other  
 $\Rightarrow OC \perp AB$   
 $\therefore$  Area of  $\triangle ABC$   
 $= \frac{1}{2} \times AB \times OC = \frac{1}{2} \times 14 \text{ cm} \times 7 \text{ cm} = 49 \text{ cm}^2$   
 Again OD = OA = 7 cm  
 $\therefore$  Radius of the small circle  
 $= \frac{1}{2} (OD) = \frac{1}{2} \times 7 = \frac{7}{2} \text{ cm}$   
 $\therefore$  Area of the small circle =  $\pi r^2$   
 $= \frac{22}{7} \times \frac{7}{2} \times \frac{7}{2} \text{ cm}^2 = \frac{11 \times 7}{2} = \frac{77}{2} \text{ cm}^2$   
 Radius of the big circle =  $\frac{14}{2} \text{ cm} = 7 \text{ cm}$

Area of the semi-circle OACB =  $\frac{1}{2} \pi r^2$   
 $= \frac{1}{2} \left( \frac{22}{7} \times 7 \times 7 \right) \text{ cm}^2$   
 $= 11 \times 7 \text{ cm}^2 = 77 \text{ cm}^2$   
 Now, Area of the shaded region  
 $= [\text{Area of the small circle}] + [\text{Area of the big semi-circle OACB}] - [\text{Area of } \triangle ABC]$   
 $= \frac{77}{2} \text{ cm}^2 + 77 \text{ cm}^2 - 49 \text{ cm}^2$   
 $= \frac{77 + 154 - 98}{2} \text{ cm}^2$   
 $= \frac{231 - 98}{2} \text{ cm}^2 = \frac{133}{2} \text{ cm}^2 = 66.5 \text{ cm}^2$

10. The area of an equilateral triangle ABC is  $17320.5 \text{ cm}^2$ . With each vertex of the triangle as centre, a circle is drawn with radius equal to half the length of the side of the triangle. Find the area of the shaded region. (Use  $\pi = 3.14$  and  $\sqrt{3} = 1.73205$ )

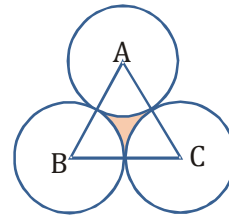

**Sol.**

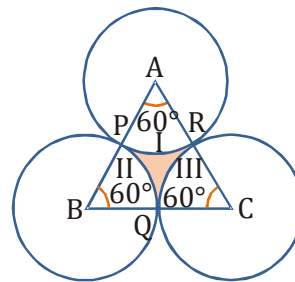

Area of the  $\triangle ABC$  (equilateral) =  $17320.5 \text{ cm}^2$   
 Let the side of the equilateral  $\triangle ABC$  be  $x \text{ cm}$ .  
 Then,  $\frac{\sqrt{3}}{4} \times x^2 = 17320.5$   
 $\Rightarrow \frac{1.73205}{4} \times x^2 = 17320.5$

$$(\because \sqrt{3} = 1.73205)$$

$$\Rightarrow x^2 = 40000 \Rightarrow x = 200 \text{ cm}$$

Then, radius of each circle = 100 cm.

Area of the sector APR

$$= \frac{60}{360} \times \pi \times (100)^2 \text{ cm}^2 = \frac{\pi}{6} \times 10000 \text{ cm}^2$$

Similarly, area of the sector BPQ = area of the sector CQR =  $\frac{\pi}{6} \times 10000 \text{ cm}^2$

Total area of regions I, II and III (i.e., non-shaded region of  $\Delta ABC$ )

$$= 3 \times \frac{\pi}{6} \times 10000 \text{ cm}^2 = \frac{1}{2} \times 3.14 \times 10000 \text{ cm}^2 = 15700 \text{ cm}^2$$

Then, the required area of the shaded region of  $\Delta ABC$

$$= \text{Area of triangle} - \text{Area of unshaded region} = 17320.5 \text{ cm}^2 - 15700 \text{ cm}^2 = 1620.5 \text{ cm}^2$$

11. On a square handkerchief, nine circular designs each of radius 7 cm are made. Find the area of the remaining portion of the handkerchief.

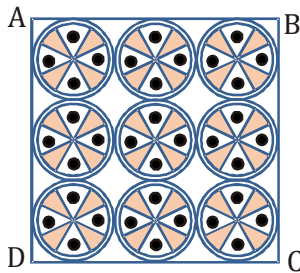

Sol.  $\because$  The circles touch each other.

$$\begin{aligned} \therefore \text{The side of the square } ABCD &= 3 \times \text{diameter of a circle} \\ &= 3 \times (2 \times \text{radius of a circle}) = 3 \times (2 \times 7 \text{ cm}) \\ &= 42 \text{ cm} \\ \Rightarrow \text{Area of the square } ABCD &= 42 \times 42 \text{ cm}^2 \\ &= 1764 \text{ cm}^2. \end{aligned}$$

Now, area of one circle =  $\pi r^2$

$$\Rightarrow \frac{22}{7} \times 7 \times 7 \text{ cm}^2 = 154 \text{ cm}^2$$

$\therefore$  There are 9 circles

$$\therefore \text{Total area of 9 circles} = 154 \times 9 = 1386 \text{ cm}^2$$

$$\therefore \text{Area of the remaining portion of the handkerchief} = (1764 - 1386) \text{ cm}^2 = 378 \text{ cm}^2.$$

12. In fig, OACB is a quadrant of a circle with centre O and radius 3.5 cm. If OD = 2 cm, find the area of the (i) quadrant OACB, (ii) shaded region.

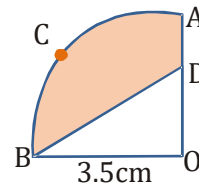

Sol. (i) Area of the quadrant OACB (radius =  $\frac{7}{2}$  cm)

$$\begin{aligned} &= \frac{1}{4} \times \pi \times r^2 = \frac{1}{4} \times \frac{22}{7} \times \left(\frac{7}{2}\right)^2 \text{ cm}^2 \\ &= \frac{1}{4} \times \frac{22}{7} \times \frac{49}{4} \text{ cm}^2 = \frac{11 \times 7}{8} \text{ cm}^2 \\ &= \frac{77}{8} \text{ cm}^2 \end{aligned}$$

(ii) In right angled  $\Delta OBD$ ,

$$OB = \frac{7}{2} \text{ cm}, OD = 2 \text{ cm}$$

$$\text{The area of } \Delta OBD = \frac{1}{2} \times OB \times OD$$

$$= \frac{1}{2} \times \frac{7}{2} \times 2 \text{ cm}^2 = \frac{7}{2} \text{ cm}^2$$

Then area of the shaded region = The area of quadrant OACB - The area of  $\Delta OBD$

$$\begin{aligned} &= \frac{77}{8} \text{ cm}^2 - \frac{7}{2} \text{ cm}^2 = \frac{77 - 28}{8} \text{ cm}^2 = \frac{49}{8} \text{ cm}^2 \\ &= 6.125 \text{ cm}^2 \end{aligned}$$

13. In fig., a square OABC is inscribed in a quadrant OPBQ. If OA = 20 cm, find the area of the shaded region. (Use  $\pi = 3.14$ )

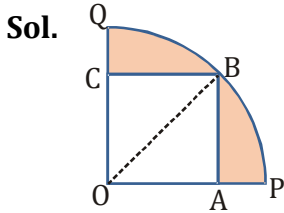
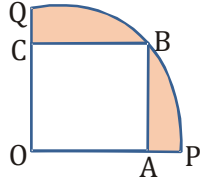

OABC is a square such that its side OA = 20 cm

$$\therefore OA = 20 \text{ cm}$$

$$\therefore OB^2 = OA^2 + AB^2$$

$$\therefore OB^2 = 20^2 + 20^2$$

$$= 400 + 400 = 800$$

$$OB = \sqrt{800} = 20\sqrt{2} \text{ cm}$$

$$\text{Now, area of the quadrant OPBQ} = \frac{1}{4} \pi r^2$$

$$= \frac{1}{4} \times \frac{314}{100} \times 800 \text{ cm}^2 = 314 \times 2 = 628 \text{ cm}^2$$

$$\begin{aligned} \text{Area of the square OABC} &= 20 \times 20 \text{ cm}^2 \\ &= 400 \text{ cm}^2 \end{aligned}$$

$\therefore$  Area of the shaded region = Area of the quadrant OPBQ - Area of the square OABC

$$= 628 \text{ cm}^2 - 400 \text{ cm}^2 = 228 \text{ cm}^2$$

14. AB and CD are respectively arcs of two concentric circles of radii 21 cm and 7 cm and centre O. If  $\angle AOB = 30^\circ$ , find the area of the shaded region.

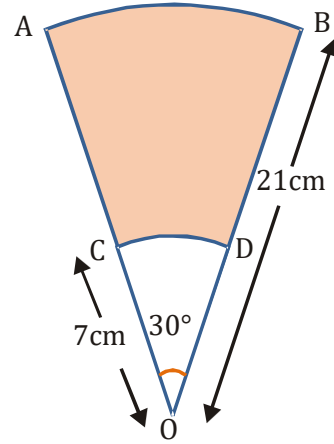

- Sol.** Radius of bigger circle R = 21 cm and sector angle  $\theta = 30^\circ$

$$\therefore \text{Area of the sector OAB}$$

$$= \frac{30^\circ}{360^\circ} \times \frac{22}{7} \times 21 \times 21 \text{ cm}^2$$

$$= \frac{11 \times 21}{2} \text{ cm}^2$$

$$= \frac{231}{2} \text{ cm}^2$$

Again, radius of the smaller circle,  $r = 7$  cm

Also, the sector angle is  $30^\circ$

$$\therefore \text{Area of the sector OCD}$$

$$= \frac{30^\circ}{360^\circ} \times \frac{22}{7} \times 7 \times 7 \text{ cm}^2$$

$$= \frac{77}{6} \text{ cm}^2$$

$\therefore$  Area of the shaded region = Area of the sector OAB - Area of the sector OCD

$$= \left( \frac{231}{2} - \frac{77}{6} \right) \text{ cm}^2 = \frac{693 - 77}{6} \text{ cm}^2$$

$$= \frac{616}{6} \text{ cm}^2 = \frac{308}{3} \text{ cm}^2$$

$$= 102.67 \text{ cm}^2$$

15. In fig., ABC is a quadrant of a circle of radius 14 cm and a semicircle is drawn with BC as diameter. Find the area of the shaded region.

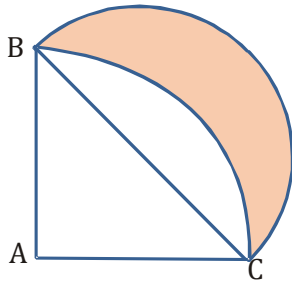

**Sol.**  $BC = \sqrt{(14)^2 + (14)^2} = 14\sqrt{2}$  cm

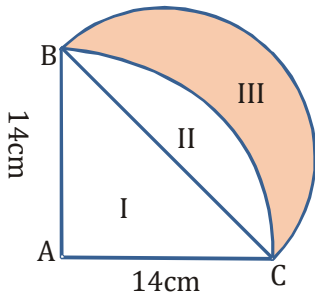

Area of region II = Area of sector ABC

– Area of  $\Delta ABC$

$$= \left\{ \frac{1}{4} \pi \times (14)^2 - \frac{1}{2} \times 14 \times 14 \right\} \text{cm}^2$$

$$= \left( \frac{1}{4} \times \frac{22}{7} \times 196 - 98 \right) \text{cm}^2$$

$$= 56 \text{ cm}^2$$

The area of the shaded region III = The area of the semicircle drawn on BC as diameter – The area of region II

$$= \left\{ \frac{1}{2} \pi \times \left( \frac{14\sqrt{2}}{2} \right)^2 - 56 \right\} \text{cm}^2$$

$$= \left( \frac{1}{2} \times \frac{22}{7} \times 98 - 56 \right) \text{cm}^2$$

$$= (154 - 56) \text{ cm}^2$$

$$= 98 \text{ cm}^2$$

- 16.** Calculate the area of the designed region in fig. common between the two quadrants of circles of radius 8 cm each.

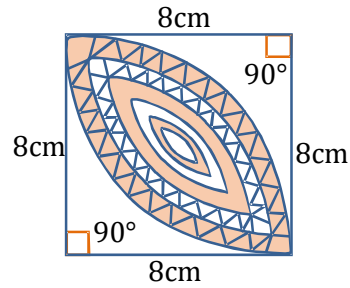

**Sol.**

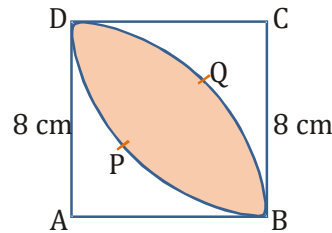

Side of the square = 8 cm

$$\therefore \text{Area of the square (ABCD)} = 8 \times 8 \text{ cm}^2 = 64 \text{ cm}^2$$

Now, radius of the quadrant ADQB = 8 cm

$\therefore$  Area of the quadrant ADQB

$$= \frac{90^\circ}{360^\circ} \times \frac{22}{7} \times 8 \times 8 \text{ cm}^2$$

$$= \frac{1}{4} \times \frac{22}{7} \times 64 \text{ cm}^2 = \frac{22 \times 16}{7} \text{ cm}^2$$

Similarly, area of the quadrant

$$BPDC = \frac{22 \times 16}{7} \text{ cm}^2$$

Sum of the two quadrant  $\text{cm}^2$

$$= 2 \left( \frac{22 \times 16}{7} \right) = \frac{704}{7} \text{ cm}^2$$

Now, area of design = (Sum of the area of two quadrant) – (Area of the square ABCD)

$$= \frac{704}{7} \text{ cm}^2 - 64 \text{ cm}^2 = \frac{704 - 448}{7} \text{ cm}^2$$

$$= \frac{256}{7} \text{ cm}^2 = 36.57 \text{ cm}^2$$